



Defense & Aerospace

RFHIC PRODUCT CATALOGUE



About RFHIC

RFHIC is a global leader in designing and manufacturing GaN-on-SiC (Gallium Nitride on Silicon Carbide) components for defense & aerospace, wireless infrastructure, and various industrial applications. In the radar industry, RFHIC is at the very forefront in providing customers with outstanding solutions for weather radars, military radars, airport surveillance radars and more. Working with RFHIC means you will benefit from our innovative engineering and dedicated service.

Our ground-breaking innovations in GaN technology offers your products the capabilities to cut through the barrier of the unimaginable into the imaginable. Come step into the future and see how we can exceed your vision.



Company & Affiliates

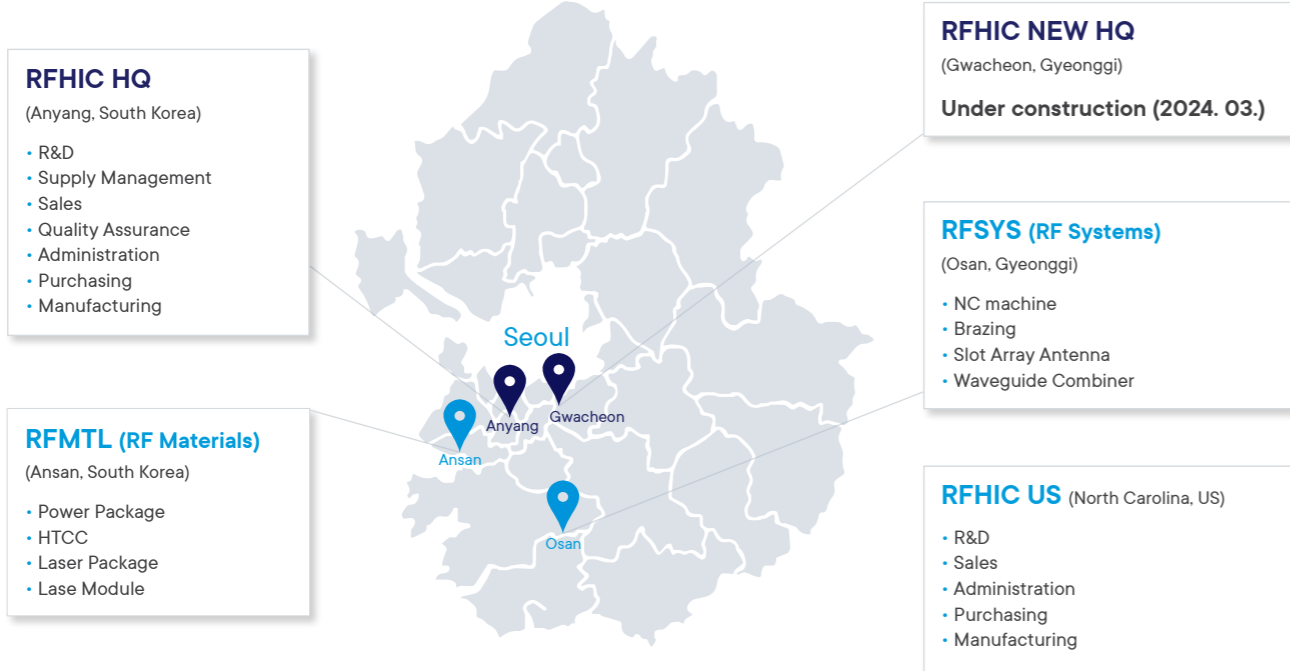

One Stop Solution

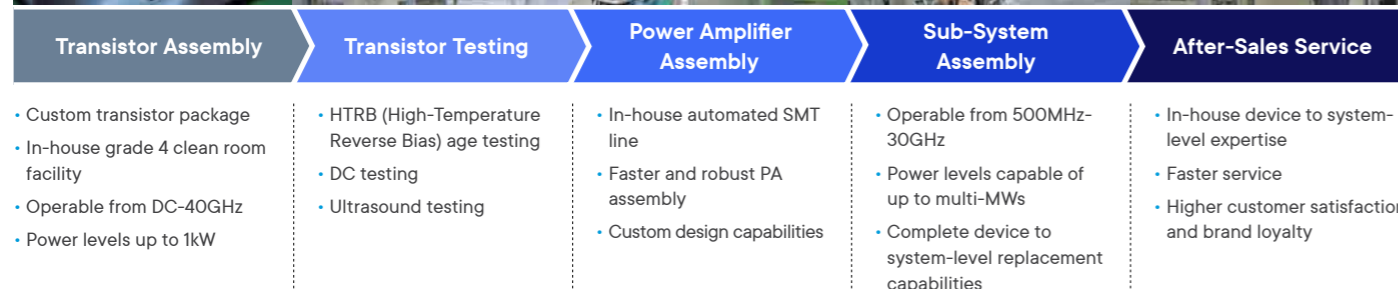

APPLICATION 01

Radars

RFHIC is at the forefront of providing customers with outstanding solutions for the radar industry's most challenging problems. We offer a broad product portfolio operable in the L/S/C/X bands for a variety of applications including weather radar, defense radar, airport surveillance radar and more.



APPLICATION 02

Electronic Warfare

RFHIC provides a full spectrum of EW(Electronic Warfare) capabilities from ground to airborne. With the utilization of RFHIC's GaN technology we can offer our customers with COTS(Commercial Off-The-Shelf) & customizable products operable in the L/S/C, and X bands.

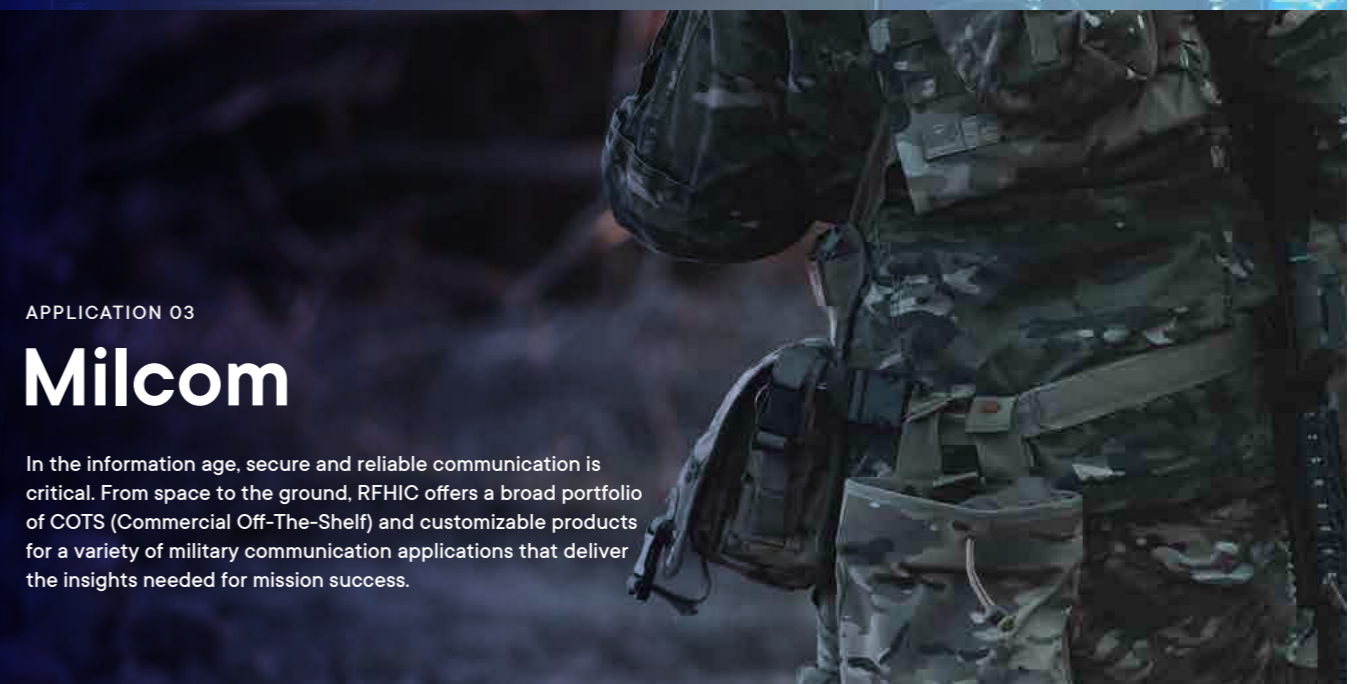

APPLICATION 03

Milcom

In the information age, secure and reliable communication is critical. From space to the ground, RFHIC offers a broad portfolio of COTS (Commercial Off-The-Shelf) and customizable products for a variety of military communication applications that deliver the insights needed for mission success.

GaN Transmit / Receive Modules

RFHIC's wide portfolio of connectorized power amplifiers covers a line of Gallium Nitride (GaN) Transmit and Receive (T/R) modules with a frequency range starting from 1.2 GHz. Our GaN T/R modules utilize our state-of-the-art GaN technology, allowing them to provide excellent output power and efficiency for radar applications. Compactly designed to occupy less space, making them the perfect solution for all AESA radar applications. Customizable solutions are available upon request.



| Part Number | Freq. [GHz] | | TX Pout | RX NF | RX Gain | TX Gain | Duty | Pulse Width | Attenuator | Phase Shifter |
|-------------|-------------|-----|---------|-------|---------|---------|------|-------------|------------|---------------|
| | Min | Max | [W] | [dB] | [dB] | [dB] | [%] | [us] | | |

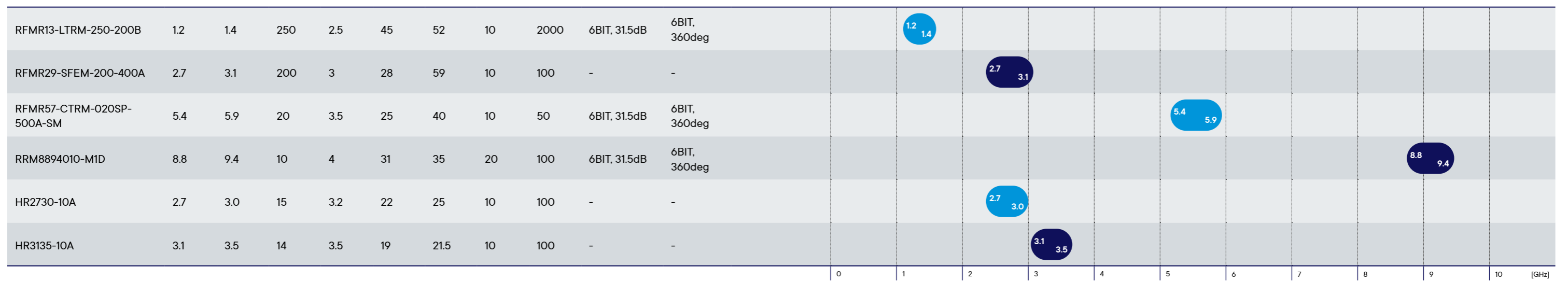

GaN SMD Modules

RFHIC offers cutting-edge GaN SMD modules fabricated for radar applications. These GaN SMD Modules offer excellent output power, high gain and high efficiency. Customizable solutions are available upon request.

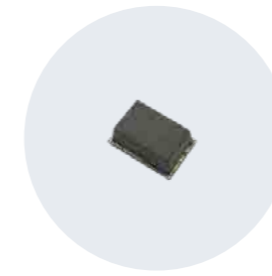

4W SMD Module
RNP04006-A1



25W C-band SMD Module
HR5459-25B



25W C-band SMD Module
HR5459-25C

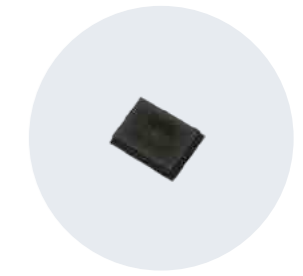

50W S-band SMD Module
HR2731-50A

| Part Number | Freq. [MHz] | | Gain | Pout | Eff. | Pulse Droop | Duty | Pulse Width | Vds | Package |
|-------------|-------------|-----|------|------|------|-------------|------|-------------|-----|---------|
| | Min | Max | [dB] | [W] | [%] | [dB] | [%] | [us] | [V] | |

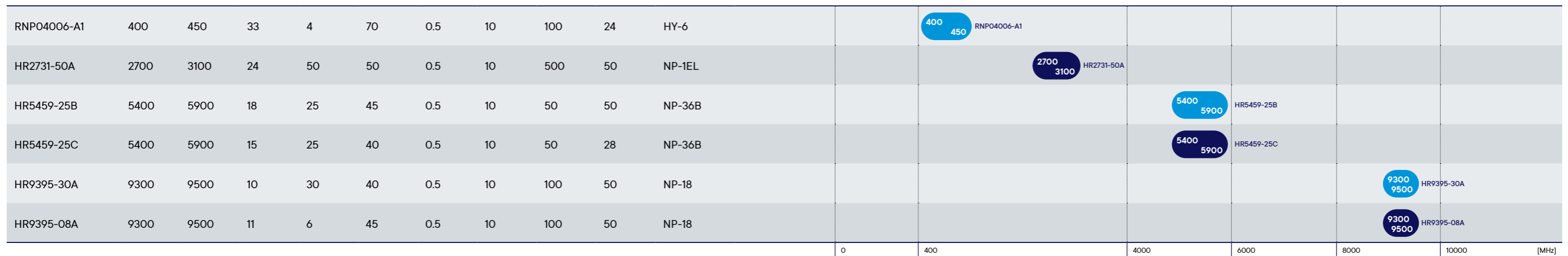

Up Down Converter

RFHIC's frequency converters are designed to offer multifunction features in a single part. Our multifunctional converters are designed to meet the demanding performance, functionality, and cost goals of current and next-generation commercial and military communication (MILCOM) applications.

| Converter Type | Part Number | Input Freq. | | Output Freq. | | Ch BW | Gain Control | Gain Step | OP1dB | NF[dB]@ Max Gain | Spurious | Power Consumption | Dimensions | Display & Control |
|--|---------------|------------------|-------|------------------|-------|---------|--------------|-----------|-------|------------------|----------|--|----------------|--|
| | | [MHz] | [MHz] | [MHz] | [MHz] | | | | | | | | | |
| Up Converter (IF [70 / 140] → RF) | RSF5767-30C0S | Center Selection | | Min | Max | 36 / 72 | 0 ~ 30 | 0.25dB | 15 | 12 | <-55 | 50Watt @90 ~ 264VAC 1Phase 50 / 60Hz | 483 x 450 x 44 | LCD, LED, Keypad RS232, RS422, LVDS, Ethernet |
| | | 70 / 140 | 5700 | 6700 | | | | | | | | | | |
| Down Converter (RF → IF [70 / 140]) | RSF3442-40C0S | Min | Max | Center Selection | | 36 / 72 | 10 ~ 40 | 0.25dB | 15 | 10 | <-55 | 50Watt @90 ~ 264VAC 1Phase 50 / 60Hz | 483 x 450 x 44 | LCD, LED, Keypad RS232, RS422, LVDS, Ethernet |
| | | 3400 | 4200 | 70 / 140 | | | | | | | | | | |

Module Amplifiers

RFHIC's broad range of connectorized power amplifiers provides users with high breakdown voltage and high efficiency for a variety of radar applications. We offer a wide portfolio of frequency ranges and power levels for both pulsed and continuous operations. Customizable solutions are available upon request.

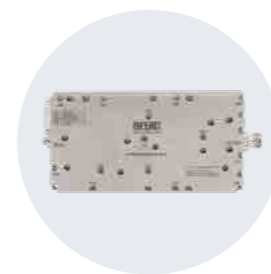

1.2kW, C-band Module Amplifier
RRP54591K2-42



200W, X-band Module Amplifier
RRM9397200-56A



90W, S-band Module Amplifier
RRP3135080-37A

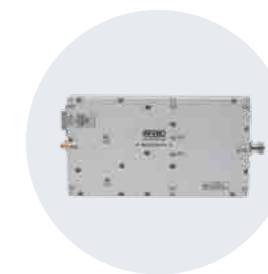

500W, X-band Module Amplifier
RRP9596500-55

| Part Number | Freq [MHz] | | Gain | Pout | Eff. | Pulse Droop | Duty | Pulse Width | Vds | Dimensions |
|-------------|------------|-----|------|------|------|-------------|------|-------------|-----|----------------|
| | Min | Max | [dB] | [W] | [%] | [dB] | [%] | [us] | [V] | W x H x D [mm] |



Transmitter Systems

RFHIC's Solid State Transmitters (SSTXs) provide a single form with high reliability and high efficiency for high-power radar applications. It features an industry-standard cabinet design and offers a wide range of options for frequency ranges, power levels, cooling methods, and so on. Customizable solutions are available upon request.



10kW, 1.0-2.0GHz, GaN SSTX

L-band RRK102010K-550

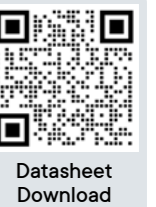

Built with RFHIC's GaN-on-SiC technology, the RRK102010K-550 transmitter is designed for high-power, L-band radar applications.

Operating from 1000 to 2000 MHz with a minimum output power of 10000 W, the RRK102010K-550 is an ideal radar component that can replace conventional vacuum electronic devices, such as klystrons, magnetrons, travelling wave tubes and cross field amplifiers.

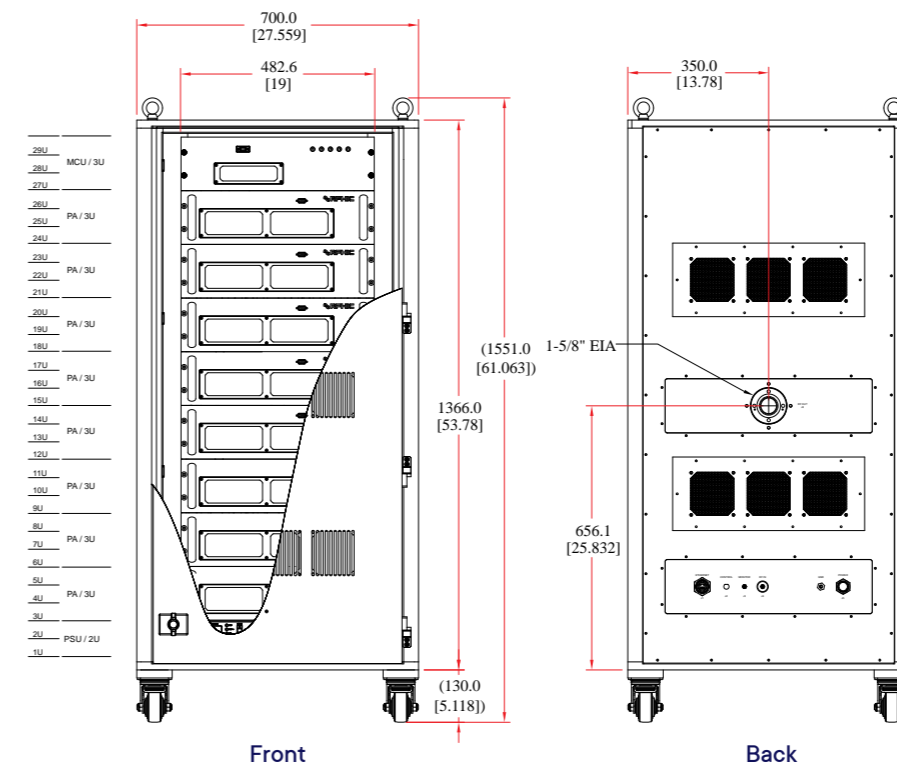

Specifications

| | |
|-----------------------------|---|
| Frequency (MHz) | 1000 ~ 2000 |
| Pout (W) | 10000 MIN |
| Gain (dB) | 55 |
| Duty (%) | 15 |
| Pulse Width (us) | 100 |
| Output Type | 1 - 5/8" EIA |
| Voltage (V) | +208VAC 3P3W, 60Hz |
| Power Consumption (kW) | 10 TYP |
| Cooling | Air |
| Dimensions (W x H x D (mm)) | 700 x 1366 x 944.5 (Height excluding wheels & eye bolts.) |

(mm)

100W, 16Channel 3.1-3.5GHz, GaN SSTX

S-band RRF3135100-500

The RRF3135100-500 is a GaN-on-SiC, transmitter operating from 3100 to 3500MHz with 16 channels of amplifiers that have an output of 100 W each. This compact transmitter can be easily mounted into various cabinet systems.

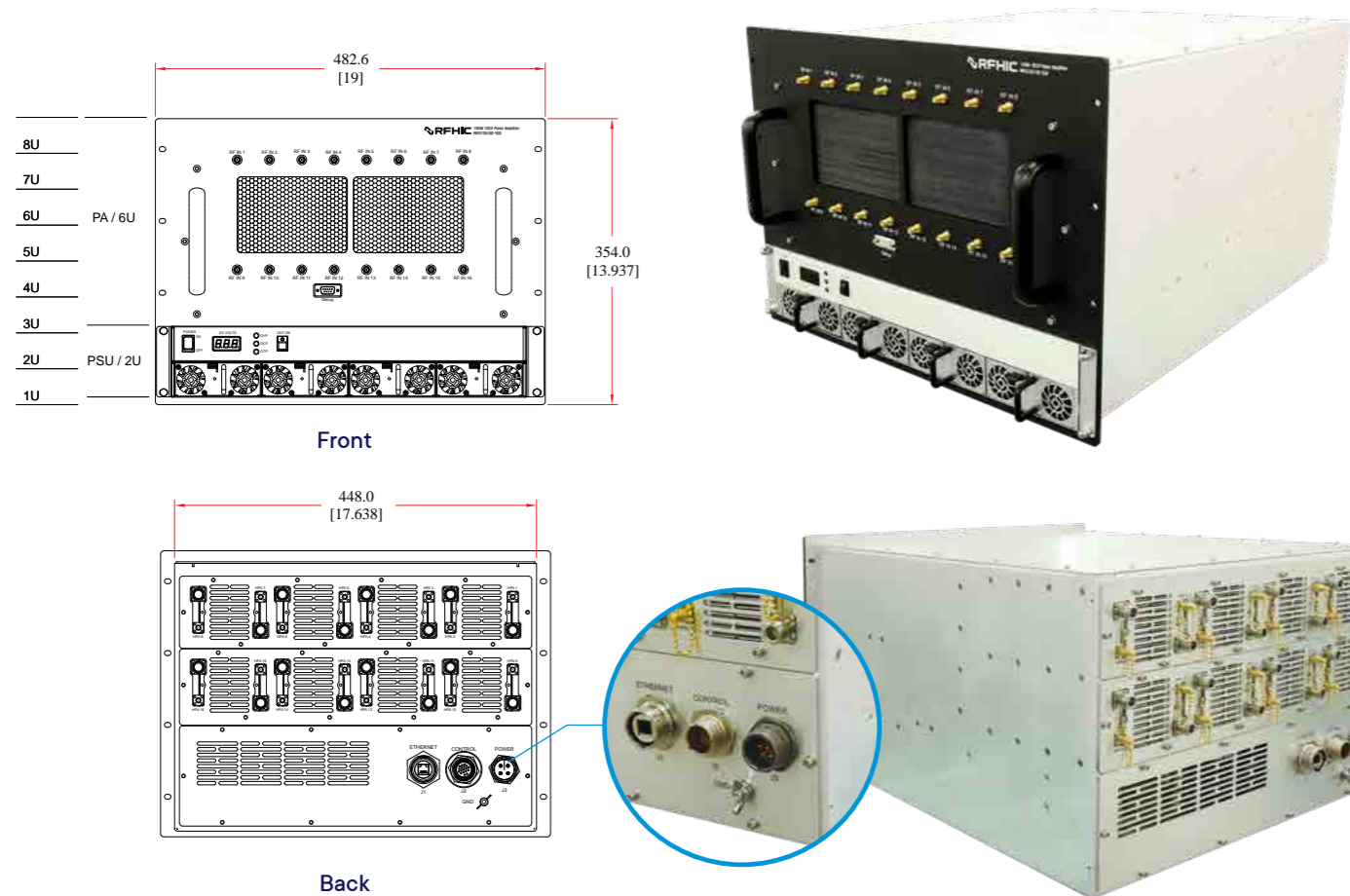

Specifications

| | |
|-----------------------------|---------------------------|
| Frequency (MHz) | 3100 ~ 3500 |
| Pout (W) | 100 TYP (16Channel) |
| Gain (dB) | 50 |
| Duty (%) | 50 |
| Pulse Width (us) | 100 |
| Output Type | N-Type(F) |
| Voltage (V) | +120 / +208VAC 3P3W, 60Hz |
| Power Consumption (kW) | 4.5 Max |
| Cooling | Air |
| Dimensions (W x H x D (mm)) | 482.6 x 354 x 655 |

4kW, 2.7-3.1GHz, GaN SSTX

S-band RRF29314K0-660

The RRF29314K0-660 is a GaN-on-SiC, S-band transmitter operating from 2900 to 3100 MHz with a minimum output power of 4000 W. This 19" (width) compact transmitter can be easily mounted into various cabinet systems.

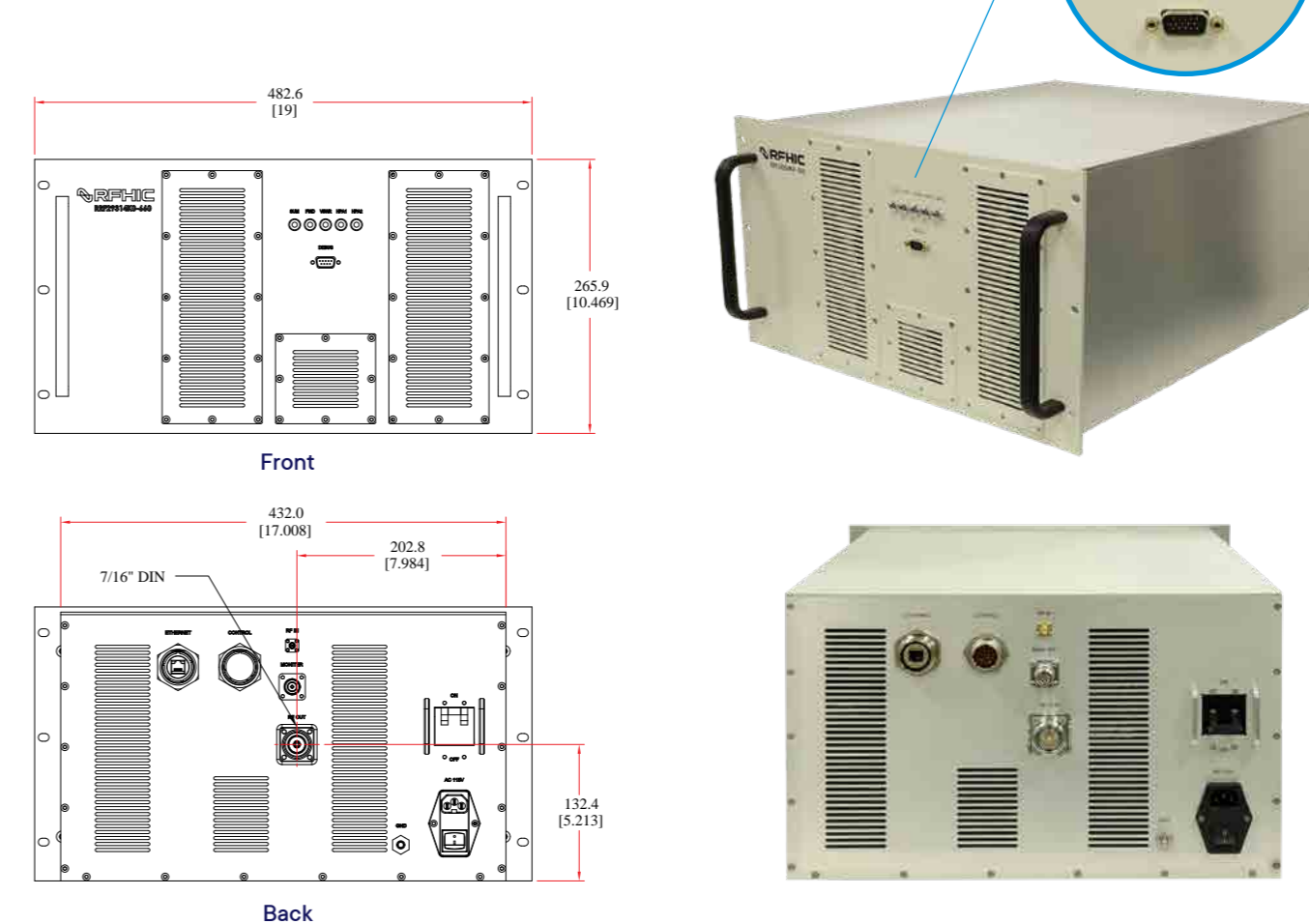

Specifications

| | |
|-----------------------------|-------------------------|
| Frequency (MHz) | 2700 ~ 3100 |
| Pout (W) | 4000 MIN |
| Gain (dB) | 66 |
| Duty (%) | 10 |
| Pulse Width (us) | 100 |
| Output Type | 7/16" DIN |
| Voltage (V) | 115VAC 1Phase 50 / 60Hz |
| Power Consumption (kW) | 2.5 Max |
| Cooling | Air |
| Dimensions (W x H x D (mm)) | 482.6 x 265.9 x 590 |

5kW, 2.0-4.0GHz, GaN SSTX

S-band **RRK20405KO-680**

Built with RFHIC's GaN-on-SiC technology, the RRK20405KO-680 transmitter is designed for high-power, S-band radar applications. Operating from 2000 to 4000 MHz with a minimum output power of 5000 W, the RRK20405KO-680 is an ideal radar component that can replace conventional vacuum electronic devices, such as klystrons, magnetrons, travelling wave tubes and cross field amplifiers.

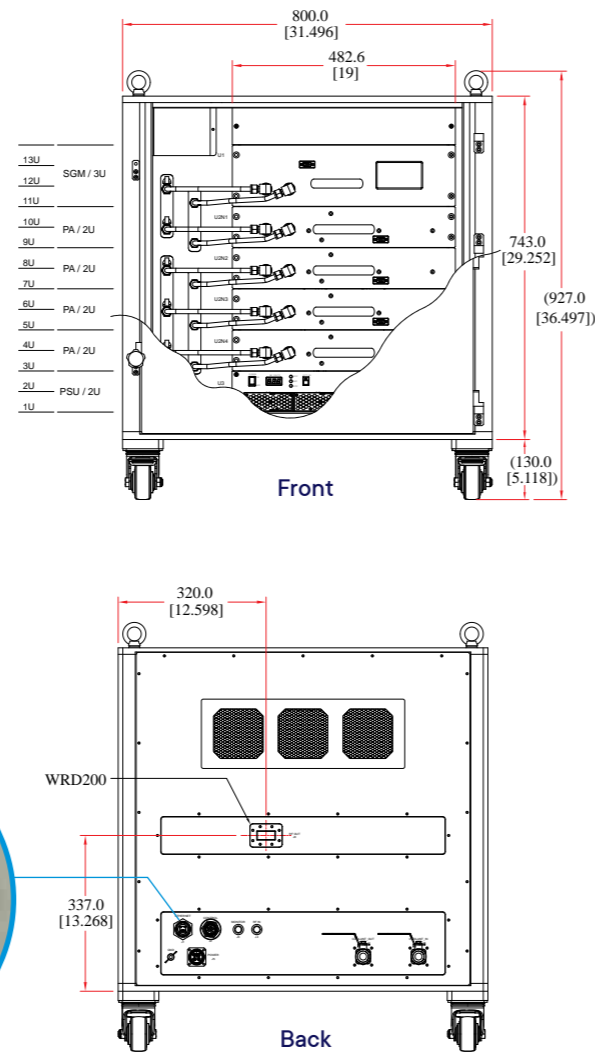

Specifications

| | |
|-----------------------------|--|
| Frequency (MHz) | 2000 ~ 4000 |
| Pout (W) | 5000 MIN |
| Gain (dB) | 52 |
| Duty (%) | 15 |
| Pulse Width (us) | 120 |
| Output Type | WRD200 |
| Voltage (V) | +208VAC 3P3W, 60Hz |
| Power Consumption (kW) | 6 TYP |
| Cooling | Water |
| Dimensions (W x H x D (mm)) | 800 x 743 x 997 (Height excluding wheels & eye bolts.) |

7.5kW, 2.7-3.1GHz, GaN SSTX

S-band **RRT27317K5-690**

Built with RFHIC's GaN-on-SiC technology, the RRT27317K5-690 is a GaN solid-state transmitter operating from 2700 to 3100 MHz with a minimum output power of 7500 W. Designed for high-power radar applications, the RRT27317K5-690 is an ideal component for airport surveillance radars, weather radars, maritime radars and more. Redundancy features are integrated into the design of the high-power amplifiers and power supply units within the transmitter, preventing single-point failures and ensuring reliable, continuous operations.

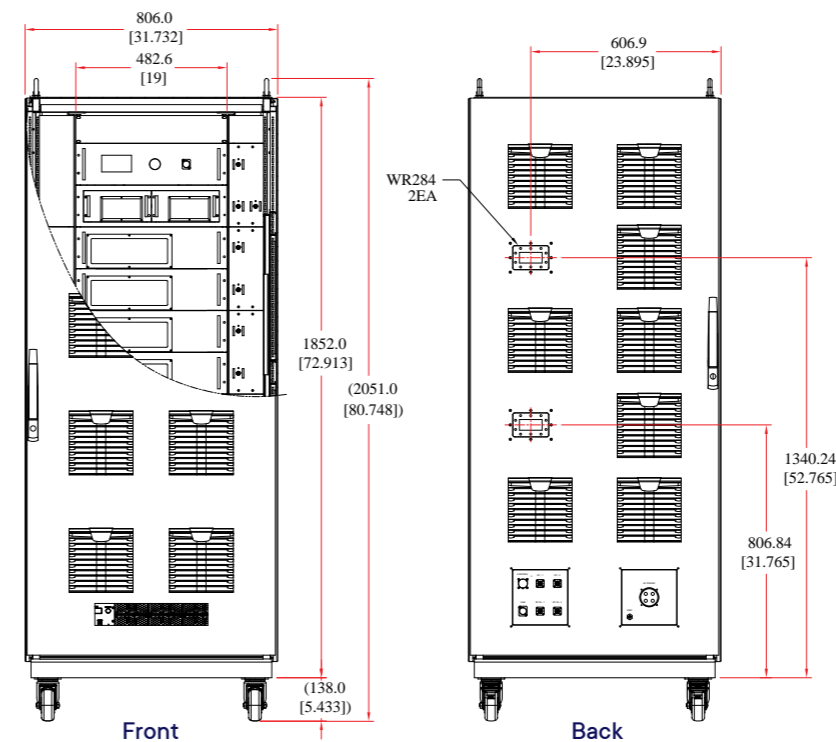

Specifications

| | |
|-----------------------------|--|
| Frequency (MHz) | 2700 ~ 3100 |
| Pout (W) | 7500 MIN (Dual port output) |
| Gain (dB) | 69 |
| Duty (%) | 10 |
| Pulse Width (us) | 100 |
| Output Type | WR284 |
| Voltage (V) | +208VAC 3P3W or +380VAC 3P4W, 60Hz |
| Power Consumption (kW) | 6 TYP |
| Cooling | Air |
| Dimensions (W x H x D (mm)) | 806 x 1852 x 1205 (Height excluding wheels & eye bolts.) |

10kW, 2.0-4.0GHz, GaN SSTX

S-band **RRK204010K-550**

Built with RFHIC's GaN-on-SiC technology, the RRK204010K-550 transmitter is designed for high-power, S-band radar applications. Operating from 2000 to 4000 MHz with an output power of 10000 W, the RRK204010K-550 is an ideal radar component that can replace conventional vacuum electronic devices, such as klystrons, magnetrons, travelling wave tubes and cross field amplifiers.

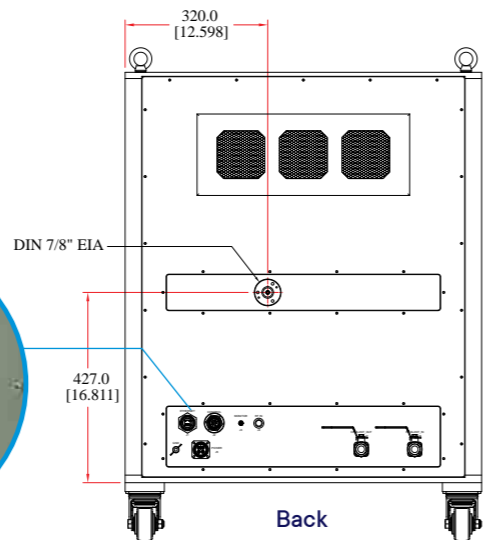
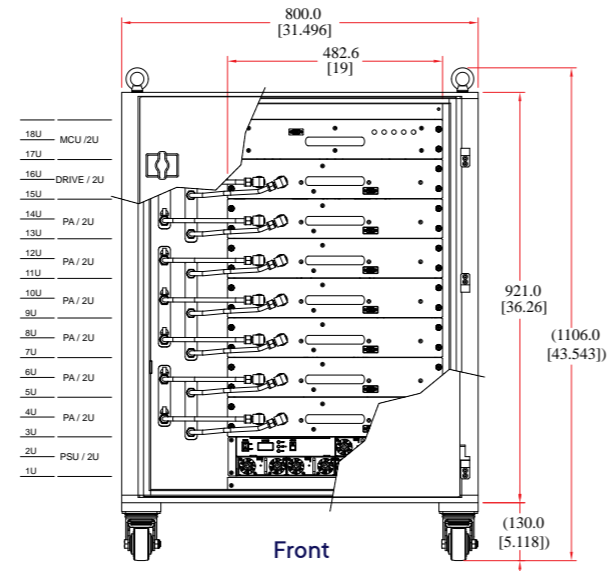

Specifications

| | |
|-----------------------------|--|
| Frequency (MHz) | 2000 ~ 4000 |
| Pout (W) | 10000 TYP |
| Gain (dB) | 55 |
| Duty (%) | 15 |
| Pulse Width (us) | 100 |
| Output Type | 7/8" EIA |
| Voltage (V) | +208VAC 3P3W, 60Hz |
| Power Consumption (kW) | 10 TYP |
| Cooling | Water |
| Dimensions (W x H x D (mm)) | 800 x 921 x 998 (Height excluding wheels & eye bolts.) |

(mm)

10kW, 2.7-3.1GHz, GaN SSTX

S-band **RRT293110K-650**

Built with RFHIC's GaN-on-SiC technology, the RRT293110K-650 transmitter is designed for high-power, S-band radar applications. Operating from 2900 to 3100 MHz with a minimum output power of 10000 W, the RRT293110K-650 is an ideal radar component that can replace conventional vacuum electronic devices, such as klystrons, magnetrons, travelling wave tubes and cross field amplifiers.

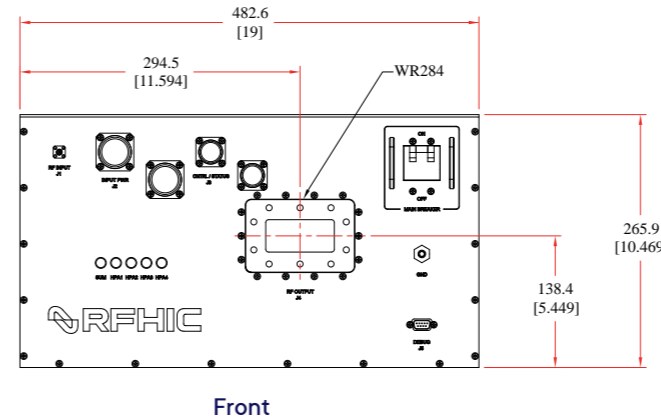

Specifications

| | |
|-----------------------------|-------------------------|
| Frequency (MHz) | 2700 ~ 3100 |
| Pout (W) | 10000 MIN |
| Gain (dB) | 65 |
| Duty (%) | 10 |
| Pulse Width (us) | 100 |
| Output Type | WR284 |
| Voltage (V) | 50VDC, 9VDC |
| Power Consumption (kW) | 4 Max |
| Cooling | Air (FAN not included.) |
| Dimensions (W x H x D (mm)) | 482.6 x 265.9 x 624.5 |

(mm)

15kW, 2.7-3.1GHz, GaN SSTX

S-band RRT273115K-690

Built with RFHIC's GaN-on-SiC technology, the RRT273115K-690 transmitter is a 15kW (minimum), S-band transmitter system operating from 2700 to 3100 MHz. The RRT273115K-690 is designed for various radar applications including airport surveillance radars, weather radars, defense radars, and more.

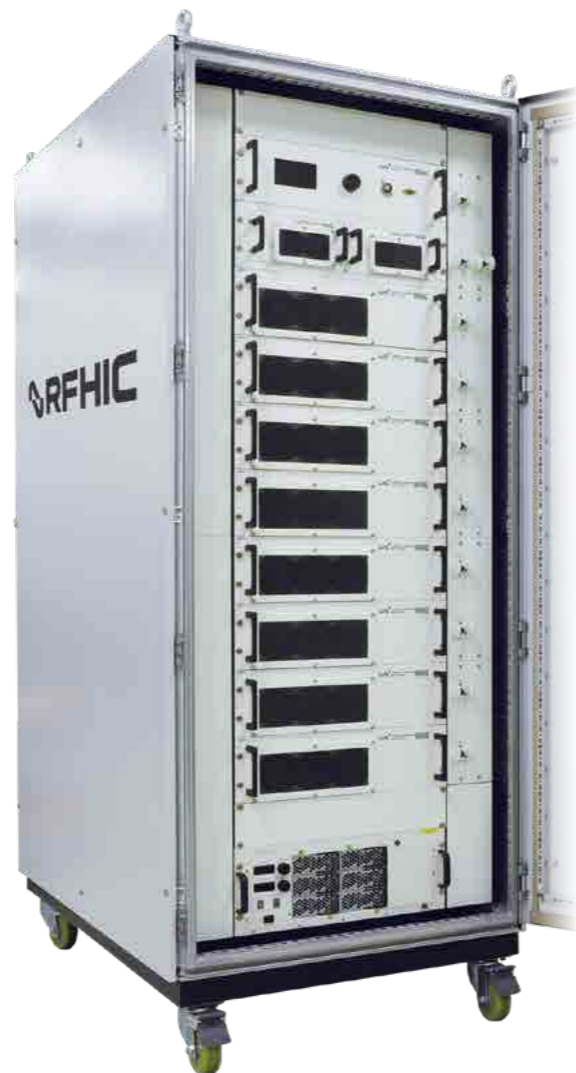
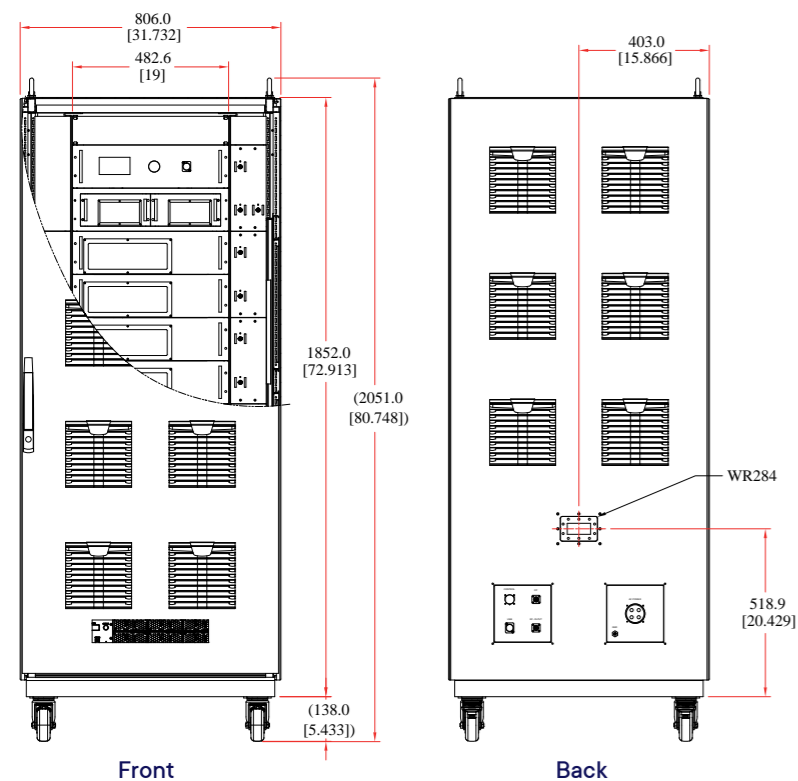

Datasheet Download

Specifications

| | |
|-----------------------------|--|
| Frequency (MHz) | 2700 ~ 3100 |
| Pout (W) | 15000 MIN |
| Gain (dB) | 72 |
| Duty (%) | 10 |
| Pulse Width (us) | 100 |
| Output Type | WR284 |
| Voltage (V) | +208VAC 3P3W or +380VAC 3P4W, 60Hz |
| Power Consumption (kW) | 6 TYP |
| Cooling | Air |
| Dimensions (W x H x D (mm)) | 806 x 1852 x 1205 (Height excluding wheels & eye bolts.) |

(mm)

5kW, 4.0-8.0GHz, GaN SSTX

C-band RRK40805KO-680

Built with RFHIC's GaN-on-SiC technology, the RRK40805KO-680 transmitter is designed for high-power, C-band radar applications. Operating from 4000 to 8000 MHz with an output power of 5000 W, the RRK40805KO-680 is an ideal radar component that can replace conventional vacuum electronic devices, such as klystrons, magnetrons, travelling wave tubes and cross field amplifiers.



Datasheet Download

Specifications

| | |
|-----------------------------|--|
| Frequency (MHz) | 4000 ~ 8000 |
| Pout (W) | 5000 |
| Gain (dB) | 52 |
| Duty (%) | 15 |
| Pulse Width (us) | 120 |
| Output Type | WRD350 |
| Voltage (V) | +208VAC 3P3W, 60Hz |
| Power Consumption (kW) | 15 TYP |
| Cooling | Water |
| Dimensions (W x H x D (mm)) | 800 x 921 x 997 (Height excluding wheels & eye bolts.) |

(mm)

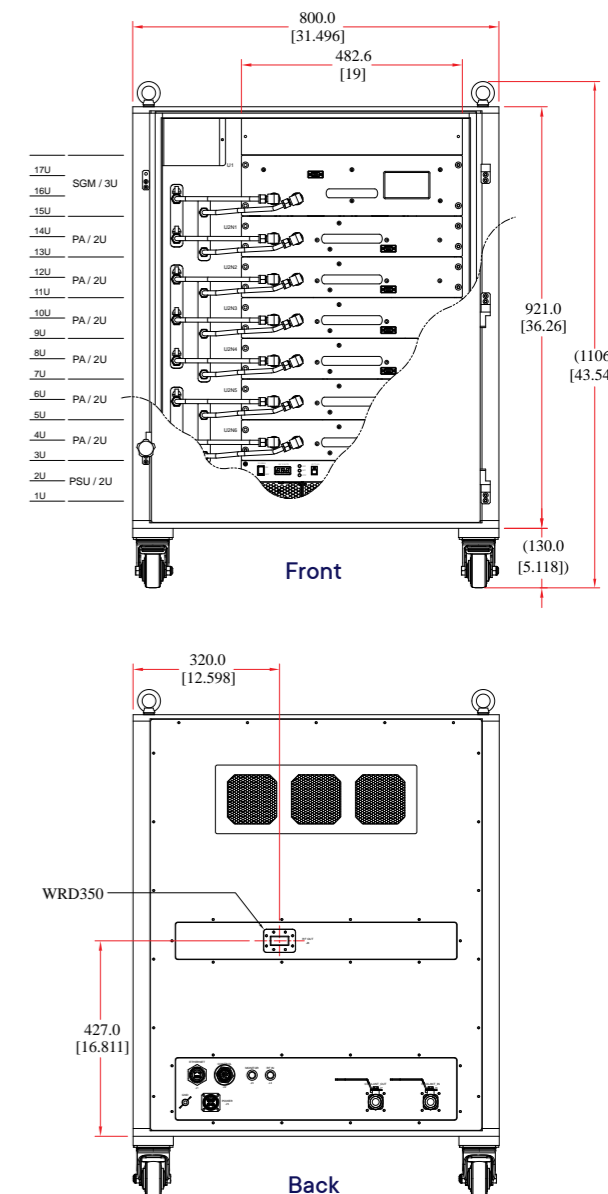

6kW, 5.4-5.9GHz, GaN SSTX

C-band **RRK54596K0-780**

Built with RFHIC's GaN-on-SiC technology, the RRK54596K0-780 transmitter is designed for high-power, C-band radar applications.

Operating from 5400 to 5900 MHz with an output power of 6000 W, the RRK54596K0-780 is an ideal radar component that can replace conventional vacuum electronic devices, such as klystrons, magnetrons, travelling wave tubes and cross field amplifiers.



Front



Back

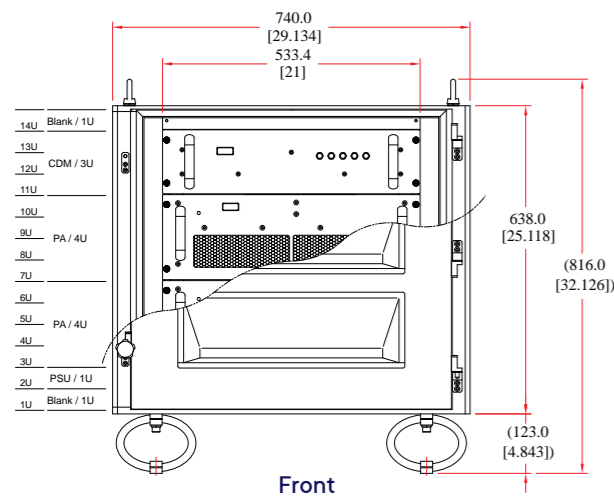

Front



Product Detail

WR187

Specifications

| | |
|-----------------------------|---|
| Frequency (MHz) | 5400 ~ 5900 |
| Pout (W) | 6000 |
| Gain (dB) | 78 |
| Duty (%) | 10 |
| Pulse Width (us) | 30 |
| Output Type | WR187 |
| Voltage (V) | +415VAC 3P4W, 50Hz |
| Power Consumption (kW) | 5 TYP |
| Cooling | Air |
| Dimensions (W x H x D (mm)) | 740 x 638 x 1075 (Height excluding wheels & eye bolts.) |

(mm)

8.5kW, 5.6-5.7GHz, GaN SSTX

C-band **RRK56578K5-790**

Built with RFHIC's GaN-on-SiC technology, the RRK56578K5-790 transmitter is designed for high-power, C-band radar applications.

Operating from 5600 to 5700 MHz with an output power of 8500 W, the RRK56578K5-790 is an ideal radar component that can replace conventional vacuum electronic devices, such as klystrons, magnetrons, travelling wave tubes and cross field amplifiers.



Front



Back

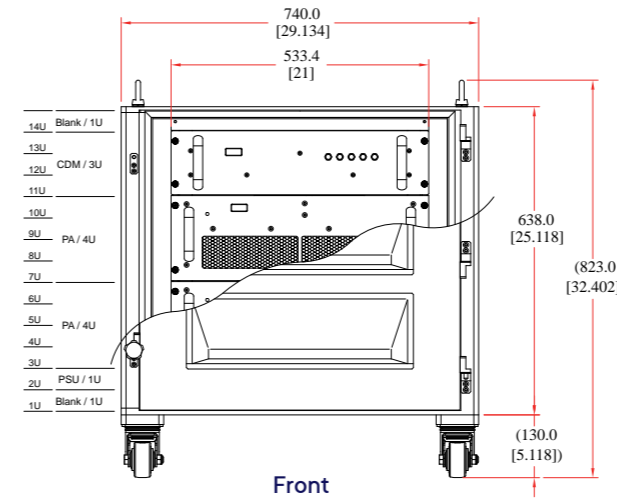

Front



Product Detail

WR159

Specifications

| | |
|-----------------------------|---|
| Frequency (MHz) | 5600 ~ 5700 |
| Pout (W) | 8500 |
| Gain (dB) | 79 |
| Duty (%) | 10 |
| Pulse Width (us) | 100 |
| Output Type | WR159 |
| Voltage (V) | +415VAC 3P4W, 50 & 60Hz |
| Power Consumption (kW) | 5 TYP |
| Cooling | Air |
| Dimensions (W x H x D (mm)) | 740 x 638 x 1075 (Height excluding wheels & eye bolts.) |

(mm)

400W, 9.3-9.7GHz, GaN SSTX



Datasheet Download

X-band RRT9397400-560

The RRT9397400-560 is a GaN-on-SiC, X-band transmitter operating from 9300 to 9700 MHz with an output power of 400 W. This 19" (width) compact transmitter can be easily mounted into various cabinet systems or masts. Equipped with a detection alarm to prevent system damage.

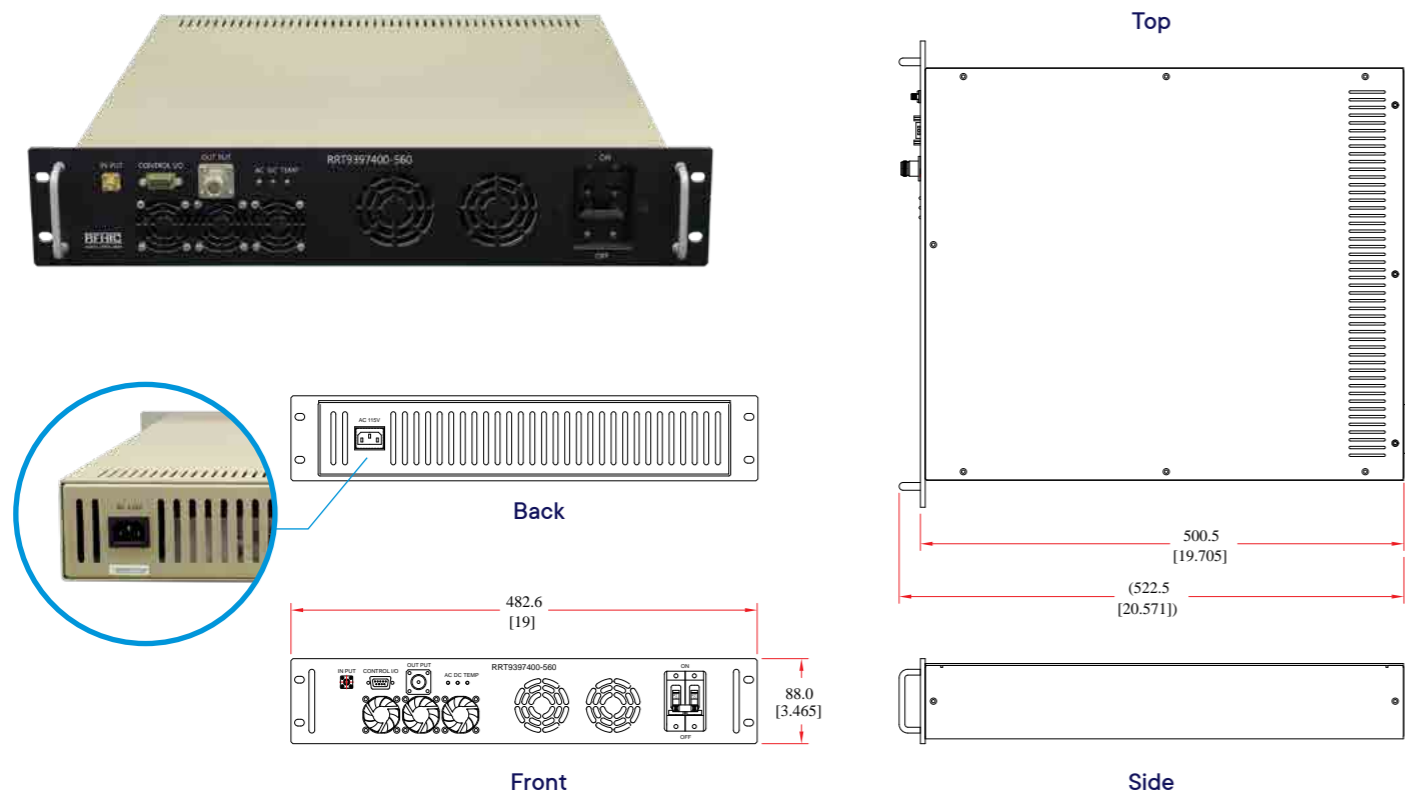

Specifications

| | |
|-----------------------------|-------------------------|
| Frequency (MHz) | 9300 ~ 9700 |
| Pout (W) | 400 |
| Gain (dB) | 56 |
| Duty (%) | 10 |
| Pulse Width (us) | 100 |
| Output Type | N-Type(F) |
| Voltage (V) | 115VAC 1Phase 50 & 60Hz |
| Power Consumption (kW) | 1 Max |
| Cooling | Air |
| Dimensions (W x H x D (mm)) | 482.6 x 88 x 522.5 |

5kW, 9.0-10.0GHz, GaN SSTX



Datasheet Download

X-band RRT901005K0-570

Built with RFHIC's GaN-on-SiC technology, the RRT901005K0-570 transmitter is designed for high-power, X-band radar applications. Operating from 9000 to 10000 MHz with an output power of 5000 W, the RRT901005K0-570 is an ideal radar component that can replace conventional vacuum electronic devices, such as klystrons, magnetrons, travelling wave tubes and cross field amplifiers. Upon request, the original 1 GHz bandwidth can be adjusted to any 500 MHz segment within the 9000 MHz to 10000 MHz range.

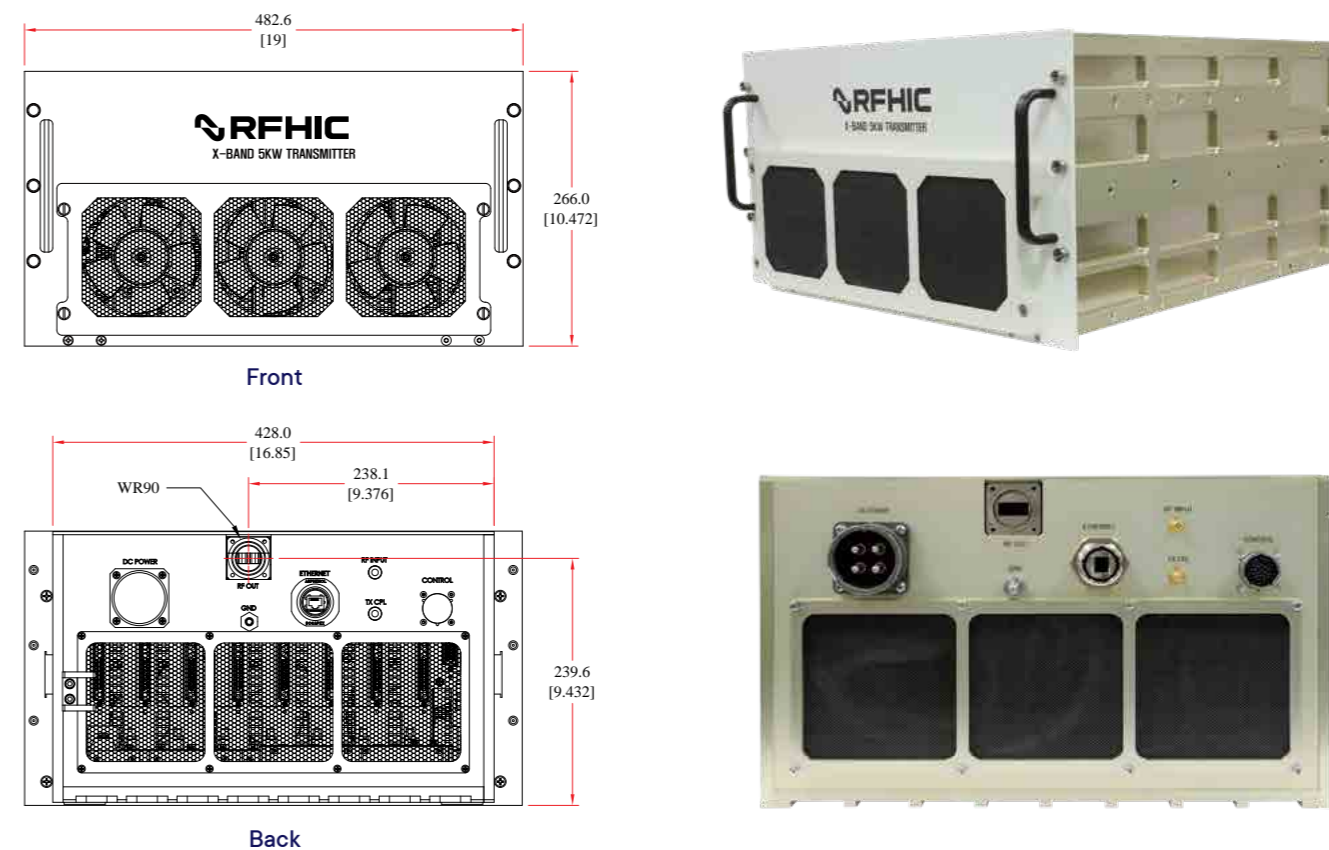

Specifications

| | |
|-----------------------------|---------------------------|
| Frequency (MHz) | 9000 ~ 10000 (BW, 500MHz) |
| Pout (W) | 5000 |
| Gain (dB) | 57 |
| Duty (%) | 10 |
| Pulse Width (us) | 100 |
| Output Type | WR90 |
| Voltage (V) | 50VDC |
| Power Consumption (kW) | 5 Max |
| Cooling | Air |
| Dimensions (W x H x D (mm)) | 482.6 x 266 x 537.5 |

Pallet Amplifiers

RFHIC's state-of-the-art GaN-on-SiC pallet amplifiers are the industry's leading components for numerous radar applications. Our world-class GaN-on-SiC pallet amplifiers deliver high efficiency and excellent thermal stability across a broad range of power levels. Customizable solutions are available upon request.

| Part Number | Freq. [MHz] | | Gain | Pout | Eff. | Pulse Droop | Duty | Pulse Width | Vds | Dimensions |
|-------------|-------------|-----|------|------|------|-------------|------|-------------|-----|----------------|
| | Min | Max | [dB] | [W] | [%] | [dB] | [%] | [us] | [V] | W x H x D [mm] |

| | | | | | | | | | | |
|---------------|------|------|----|-----|----|-----|----|------|------|--------------------|
| RRP1214550-14 | 1200 | 1400 | 14 | 550 | 65 | 0.5 | 15 | 500 | 5/50 | 86 x 60 x 12 |
| RRP2731330-09 | 2700 | 3100 | 9 | 400 | 55 | 0.5 | 20 | 500 | 50 | 50 x 25 x 12 |
| RRP2731200-08 | 2700 | 3100 | 8 | 250 | 55 | 0.5 | 20 | 500 | 38 | 50.8 x 35.8 x 11.1 |
| RRP2735160-35 | 2700 | 3500 | 35 | 180 | 40 | 0.5 | 20 | 2000 | 50 | 76 x 25 x 14 |
| RRP2731080-39 | 2700 | 3100 | 39 | 100 | 42 | 0.5 | 20 | 500 | 5/50 | 100 x 36 x 14 |



100W, S-band Pallet Amplifier
RRP2731080-39

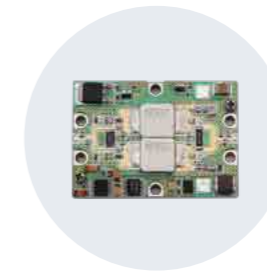

250W, S-band Pallet Amplifier
RRP2731200-08

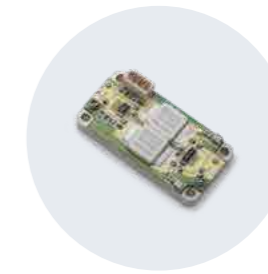

400W, S-band Pallet Amplifier
RRP2731330-09



550W, L-band Pallet Amplifier
RRP1214550-14

Frequency

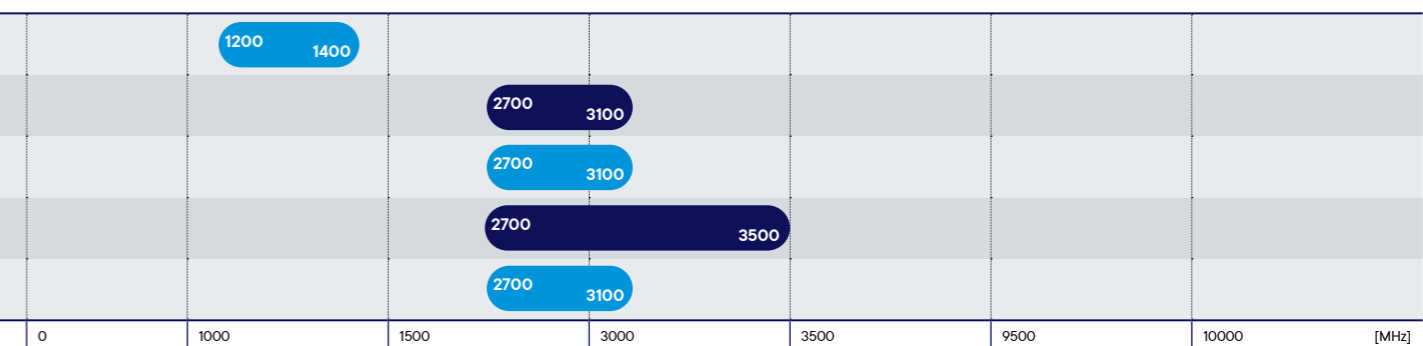

Low Noise Amplifiers

RFHIC's low noise amplifiers (LNAs) for radar applications cover a frequency range of 1200 to 3800 MHz and offer a gain range from 11.5 to 37 dB. All our LNAs are built using our GaAs pHEMT die, which is attached to a ceramic film substrate. Customizable solutions are available upon request.

| Part Number | Freq. [MHz] | | Gain | NF | P1dB | OIP3 | Vds | Idd | Maximum Input Power | Package |
|-------------|-------------|-----|------|------|-------|-------|-----|------|---------------------|---------|
| | Min | Max | [dB] | [dB] | [dBm] | [dBm] | [V] | [mA] | [dBm] | |

| | | | | | | | | | | |
|-------------|------|------|------|------|----|----|----|-----------|----|--------|
| RRM1214-R1A | 1200 | 1400 | 37 | 0.45 | 18 | - | 15 | 200 | 20 | Module |
| CL2102D-L | 1750 | 2600 | 14.5 | 0.7 | 20 | 33 | 5 | 100 | 30 | CP-16A |
| CL3102D-L | 2700 | 3500 | 11.5 | 1.1 | 20 | 33 | 5 | 100 | 30 | CP-16A |
| LCL3322-L | 2700 | 3800 | 21 | 1.4 | 27 | 39 | 5 | 190 ~ 250 | 18 | CP-16B |

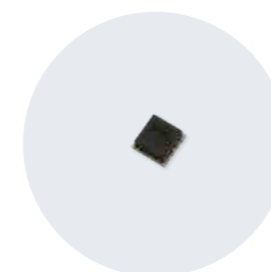

S-band, LNA 1750-2600MHz
CL2102D-L



S-band, LNA 2700-3500MHz
CL3102D-L



S-band, LNA 2700-3800MHz
LCL3322-L

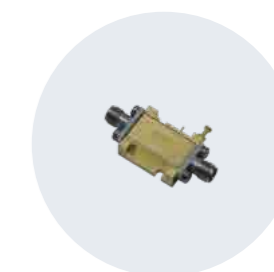

L-band, 1200-1400MHz
RRM1214-R1A

Frequency

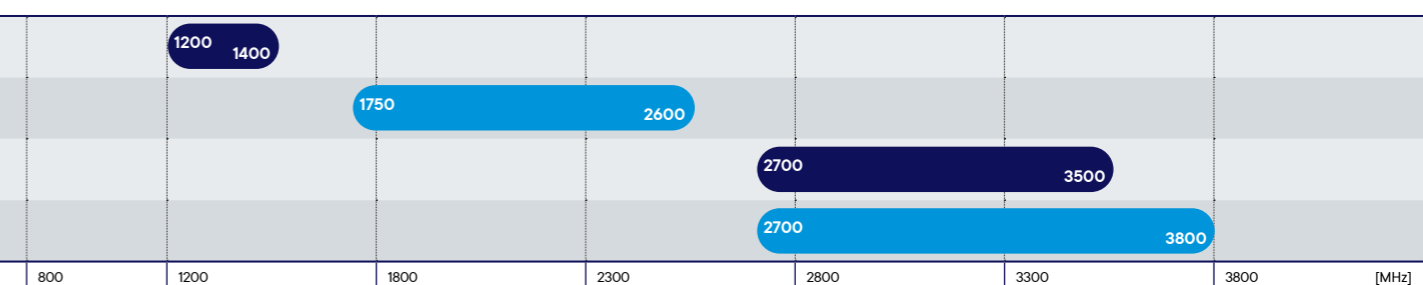

Wideband Amplifiers

In the air, on land, and at sea, our GaN-on-SiC amplifiers offer continuous amplification with excellent harmonics and exceptional wideband performance for EW (Electronic Warfare) defense applications. See and experience how we can meet today's most challenging defense problems with both our standard and custom solutions.



100W, 2000-6000MHz
GaN Wideband Power Amplifier
RWP2060080-50



40W, 500-1000MHz
GaN Wideband Power Amplifier
RWP06040-60



20W, 100-600MHz
GaN Wideband Power Amplifier
RWS02520-1K



200W, 1000-2500MHz
GaN Wideband Power Amplifier
RWP1027200-53

| Part Number | Freq. [MHz] | | Output Power | POUT | Gain | Dimensions |
|-------------|-------------|-----|--------------|-------|------|----------------|
| | Min | Max | [W] | [dBm] | [dB] | W x H x D [mm] |

| | | | | | | |
|---------------|------|------|-----|------|------|-------------------|
| RWP03040-50 | 20 | 500 | 40 | 46 | 39 | 70 x 50.8 x 17.1 |
| RWP03160-10 | 20 | 500 | 160 | 52 | 43 | 120 x 65 x 16.7 |
| RWS02520-10 | 20 | 512 | 20 | 43 | 41 | 63 x 38 x 14.4 |
| RWS02540-10 | 20 | 512 | 40 | 46 | 44 | 63 x 38 x 14.4 |
| RWP03060-10 | 20 | 512 | 80 | 49 | 38 | 72 x 50.8 x 16.8 |
| RWP03040-10 | 20 | 520 | 40 | 46 | 42 | 70 x 50.8 x 17.3 |
| RWM03060-10 | 20 | 520 | 80 | 49 | 55 | 162.6 x 86.4 x 27 |
| RWM03125-10 | 20 | 520 | 125 | 51 | 55 | 162.6 x 86.4 x 27 |
| RWP03160-2R | 20 | 800 | 150 | 51.8 | 41.8 | 120 x 65 x 16.7 |
| RWP05020-10 | 20 | 1000 | 20 | 43 | 40 | 70 x 50.8 x 17.3 |
| RWP05040-10 | 20 | 1000 | 40 | 46 | 38 | 70 x 50.8 x 17.3 |
| RFW2500H10-28 | 20 | 2500 | 4 | 36 | 17 | 38 x 50.8 x 12.5 |
| RWM03125-20 | 50 | 520 | 125 | 51 | 55 | 162.6 x 86.4 x 27 |
| RWS02520-1K | 100 | 600 | 20 | 43 | 46 | 63 x 38 x 14.4 |
| RWS05520-10 | 420 | 470 | 40 | 46 | 40 | 63 x 47 x 14.4 |
| RWP06040-10 | 450 | 880 | 30 | 45 | 40 | 70 x 50.8 x 17.1 |
| RWP06040-60 | 500 | 1000 | 40 | 46 | 42 | 90 x 75 x 25 |
| RWP15040-10 | 500 | 2500 | 50 | 47 | 38 | 72 x 50.8 x 16.8 |
| RWP15040-1H | 500 | 2500 | 50 | 47 | 38 | 98.8 x 75 x 25 |
| RWP0809300-55 | 700 | 1000 | 500 | 57 | 57 | 220 x 180 x 27.1 |
| RWP15080-10 | 700 | 2500 | 100 | 50 | 53 | 134 x 105 x 30 |
| RWP17050-10 | 700 | 2700 | 50 | 47 | 37 | 72 x 50.8 x 16.8 |
| RWP15080-20 | 700 | 2700 | 100 | 50 | 53 | 134 x 105 x 30 |
| RWP15020-50 | 1000 | 2000 | 20 | 43 | 29 | 70 x 50.8 x 17.1 |
| RWP1027200-53 | 1000 | 2500 | 200 | 53 | 50 | 223 x 131 x 30 |
| RWP20050-10 | 1000 | 3000 | 50 | 47 | 38 | 72 x 50.8 x 16.8 |
| RWP25020-50 | 2000 | 3000 | 25 | 44 | 25 | 70 x 50.8 x 17.1 |
| RUM43020-10 | 2000 | 6000 | 20 | 43 | 35 | 170 x 64 x 21.5 |
| RWP2060050-48 | 2000 | 6000 | 65 | 48 | 48 | 175 x 90 x 23 |
| RWP2060080-50 | 2000 | 6000 | 100 | 50 | 50 | 175 x 90 x 23 |
| RUM43010-10 | 2500 | 6000 | 10 | 40 | 29 | 130 x 64 x 21.5 |

Frequency

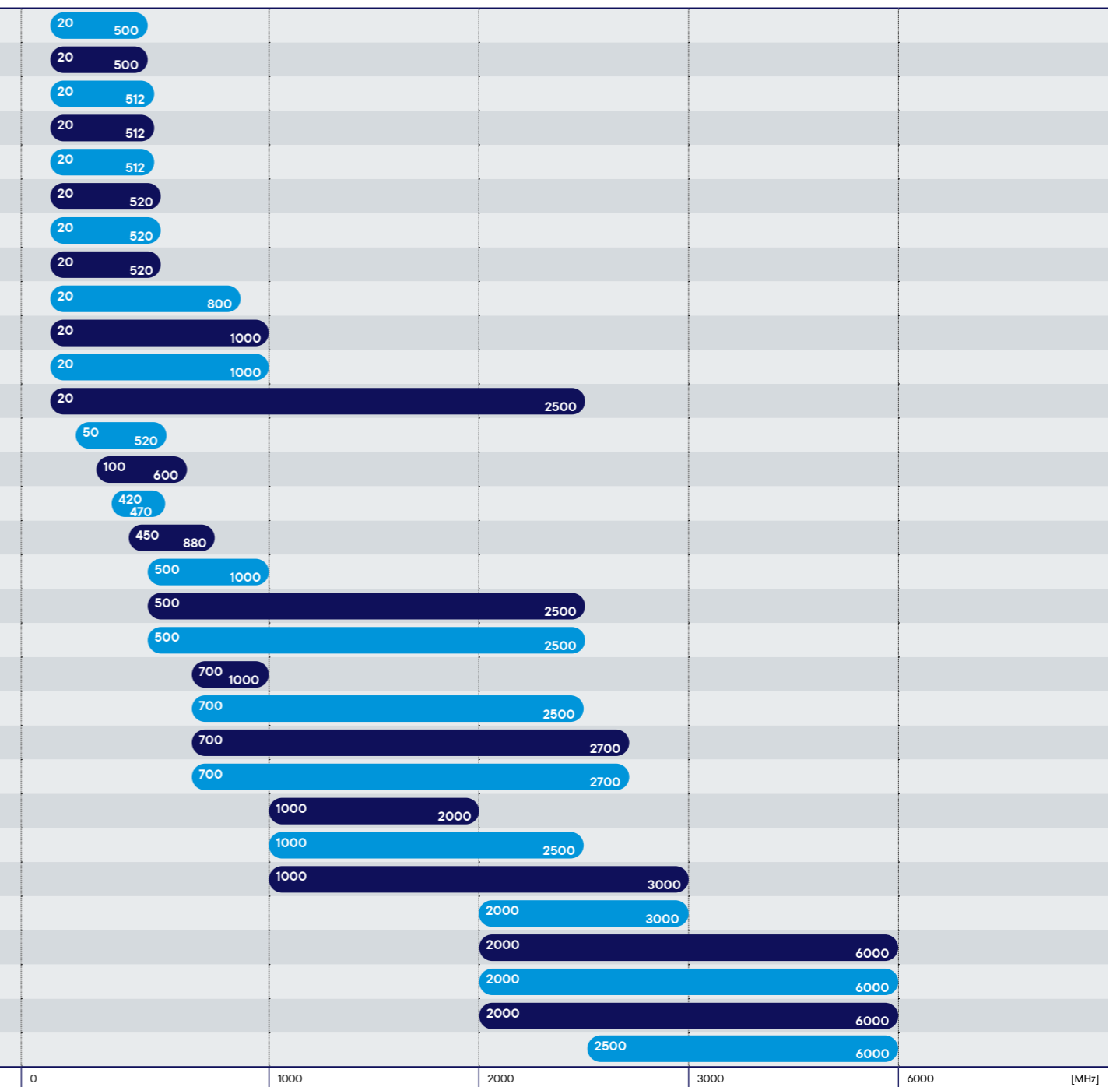

Military Communications

In today's defense systems, military industries require the highest level of reliability, performance, and cost-effectiveness. At RFHIC we strive to deliver users with the most cutting-edge quality of GaN-based products for exceptional military communication applications.

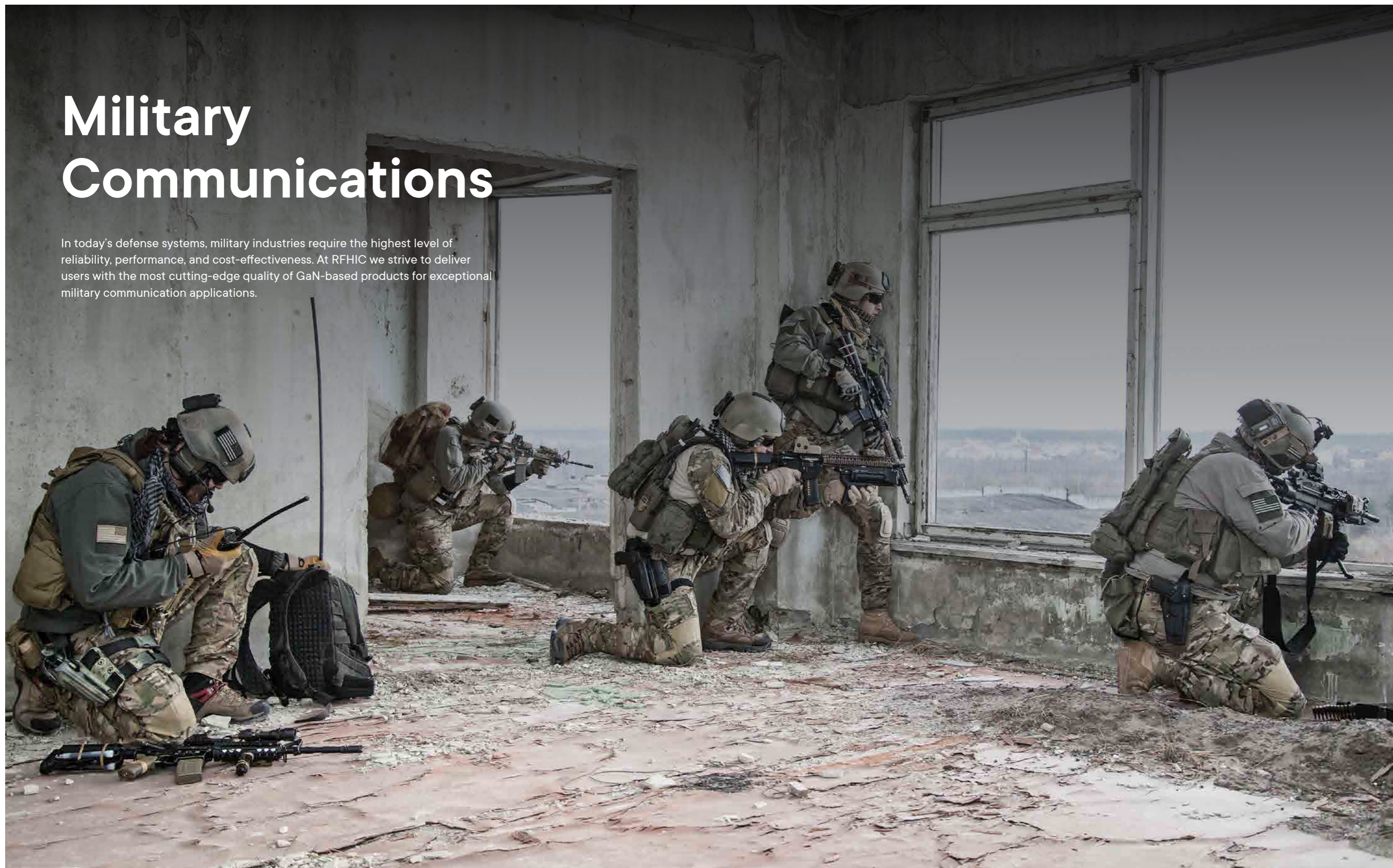

GaN SMD Modules

RFHIC's portfolio of GaN SMD modules supports the demanding requirements of today's military communication systems. Our GaN SMD modules utilize our world-class, GaN-on-SiC HEMT technology, providing users with smaller sizes, lower weights, better efficiencies, higher gains, and overall lower costs. At RFHIC we offer users the flexibility to customize their systems to fit their unique requirements.

| Part Number | Freq. [MHz] | | Output Power | Eff.@P3dB | Power Gain | Vdd | Idd | Dimensions |
|-------------|-------------|------|--------------|-----------|------------|-----|------|----------------|
| | Min | Max | [W] | [%] | [dB] | [V] | [mA] | W x H x D [mm] |
| HM0005-10A | 20 | 520 | 10 | 45 | 30 | 28 | 900 | NP-1E |
| TG520-10 | 30 | 520 | 10 | 60 | 16 | 28 | 600 | NP-18 |
| TG1000-10 | 100 | 1000 | 10 | 50 | 15 | 28 | 700 | NP-18 |
| TG2000-10 | 200 | 2000 | 10 | 50 | 12 | 28 | 600 | NP-18 |
| HM0525-10A | 500 | 2500 | 10 | 30 | 20 | 28 | 1300 | NP-1E |
| HM2060-10A | 2000 | 6000 | 10 | 25 | 16 | 32 | 1400 | NP-1EL |
| HM0220-05A | 200 | 2000 | 5 | 40 | 35 | 24 | 525 | NP-1A |
| HM0225-05A | 200 | 2500 | 5 | 35 | 35 | 24 | 525 | NP-1A |
| HM0225-05B | 200 | 2500 | 5 | 31 | 34 | 24 | 670 | NP-1A |
| HM0220-03A | 200 | 2000 | 3 | 39 | 34 | 18 | 450 | NP-1A |

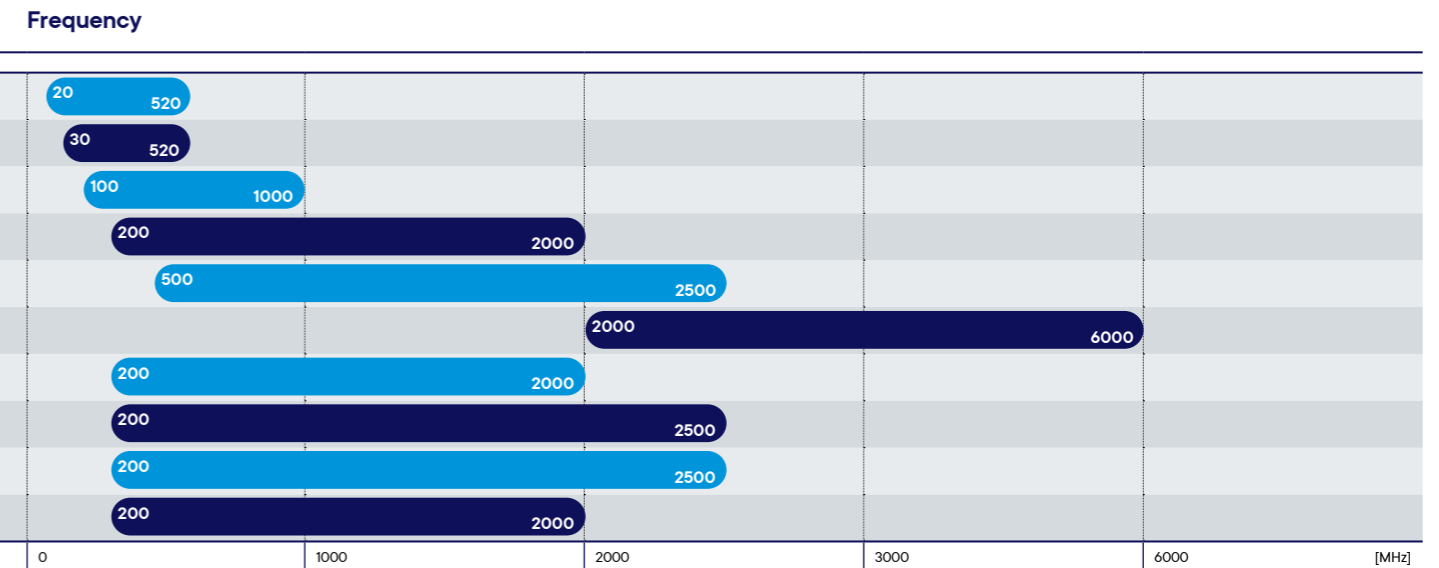

Low Noise Amplifiers

At RFHIC, we offer hybrid-type, fully matched, and low noise amplifiers operating up to 2.2 GHz. Our hybrid-type low noise amplifiers offer solutions to meet today's military communication systems' needs. Customizable solutions are available upon request.

| Part Number | Freq. [MHz] | | Gain | Flatness | NF | P1dB | OIP3 | Vdd | Idd | Package |
|-------------|-------------|------|------|----------|---------|-------|-------|-----|------|---------|
| | Min | Max | [dB] | [dB] | [dB] | [dBm] | [dBm] | [V] | [mA] | |
| WL0510 | 1 | 520 | 23 | 1.5 | 1.3~1.7 | 22 | 33 | 5 | 100 | CP-16 |
| WLP0640 | 20 | 520 | 19.5 | 1 | 2.5~3.0 | 31 | 43 | 12 | 360 | CP-6C |
| WL1008-L | 50 | 1000 | 16 | 2 | 1.5 | 19 | 31 | 5 | 100 | CP-16A |
| WL1015-L | 50 | 1000 | 16 | 2 | 1.7 | 21 | 35 | 5 | 160 | CP-16A |
| WL2205-L | 30 | 2200 | 15.5 | 1.2 | 1.4~1.7 | 15 | 26 | 5 | 50 | CP-16A |
| WL2208-L | 50 | 2200 | 15 | 4 | 1.5 | 20 | 31 | 5 | 100 | CP-16A |
| WL2215-L | 50 | 2200 | 15 | 4 | 1.7 | 21 | 35 | 5 | 160 | CP-16A |

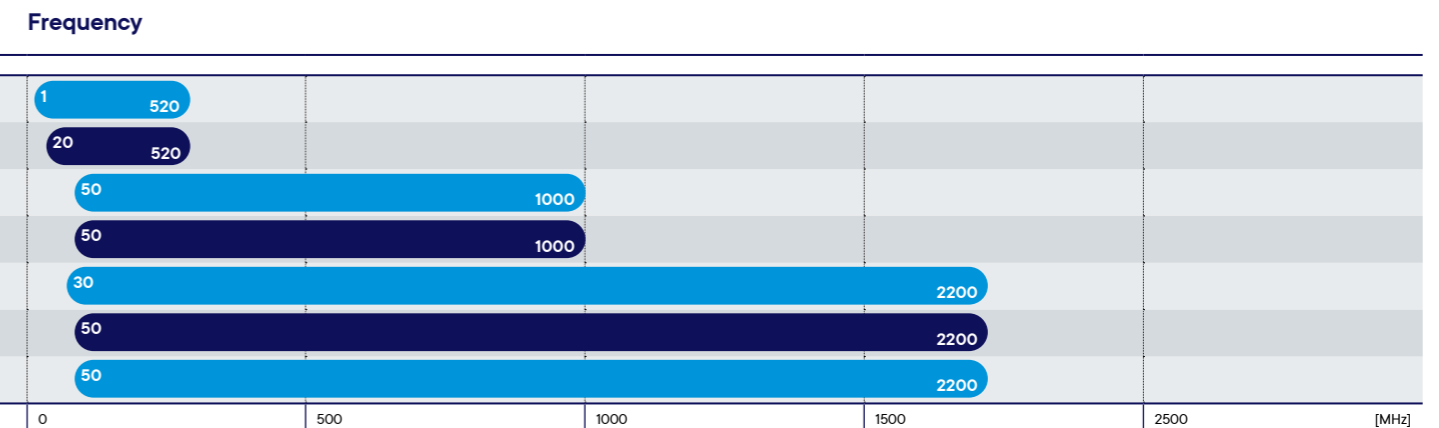
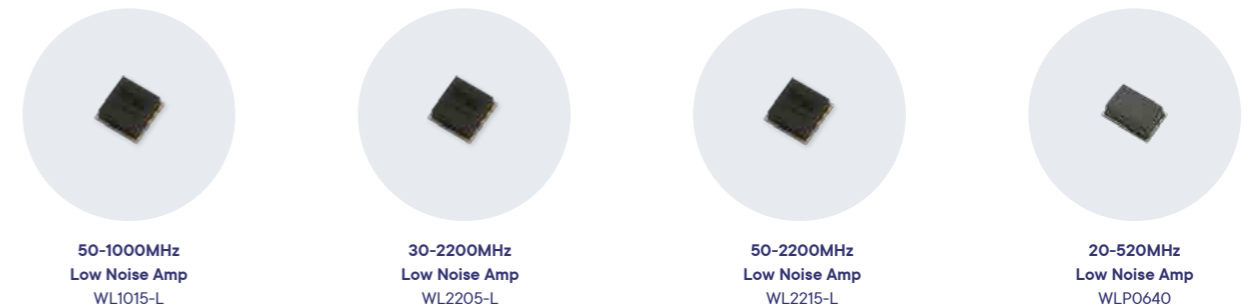



rfhic.com

 Visit us on LinkedIn